

US Navy Course NAVEDRA 14217

Chapter 4. Sewing Machine Repair

with minor editing

Table of Contents

111W155 SEWING MACHINE	2
PREVENTIVE MAINTENANCE	3
CLEANING AND OILING	3
TIMING THE 111W155 MACHINE	7
Timing the arm shaft with the hook drive shaft	7
Setting the feed dog height.....	8
Centering the feeding action	10
Timing the hook and the needle-bar	12
Timing the presser-lifting eccentric	13
ADJUSTMENTS	15
Adjusting the bobbin-case opener.....	15
Adjusting the total relative lift of the alternating pressers	16
Adjusting the relative lift of the alternating pressers.....	17
Adjusting the lifting linkage of the alternating pressers	18
Adjusting the upper thread-tension-releasing lever	18
Setting the feed indicator disk.....	19
Setting the thread controller spring.....	20
Setting the controller spring stop.....	20
Adjusting the thread tension.....	20
TROUBLESHOOTING	21
DISASSEMBLY AND REASSEMBLY OF THE 111 W 155 SEWING MACHINE	24
DISASSEMBLY	24
REASSEMBLY	34

111W155 SEWING MACHINE

The 111W155 sewing machine is a single- needle, compound-feed sewing machine with alternating presser feet. This sewing machine makes the standard US 301 lockstitch and sews medium-heavy fabrics. It is equipped with a vertical-axis rotating hook. This sewing machine is classified as a rotary sewing machine and is also equipped with two presser feet; one is a vibrating presser foot, and the other is a lifting presser foot. The front (vibrating) presser foot, the needle, and the feed dogs move in unison. Together they move the cloth away from the operator with each completed stitch. The rear (lifting) presser foot holds the fabric in place while the vibrating presser foot rises and moves forward to start the feeding action for another stitch. This sewing machine is capable of operating at a speed of 3500

stitches per minute (SPM). The stitch regulator provides a range of 3 1/2 to 32 stitches per inch (SPI).

PREVENTIVE MAINTENANCE

If the sewing machine becomes sluggish, an accumulation of dust and lint or a loose power belt may be the cause. To prevent the buildup of dust and lint, you cover the sewing machine when it is not in use.

CLEANING AND OILING

Before attempting to oil or operate a new sewing machine, clean it with diesel fuel. Diesel fuel removes any corrosion-protective lubricants that may have been placed on the sewing machine at the factory. During normal maintenance, use any approved cleaning solvent to clean the sewing machine.

After using a sewing machine, clean and oil it. A clean and well-oiled sewing machine gives many hours of trouble-free operation. Clean hard-to-reach places with a soft- bristle brush or air pressure. Clean the outside of the sewing machine head, the oil pan, the machine stand, and the motor casing with a clean dust cloth or air pressure. Never use air pressure above 25 psi for this purpose.

NOTE: At least once a year, the machine should be thoroughly cleaned and oiled. Figures 4-1 through 4-3 show the oiling points on the 111W155 sewing machine. Do not use too much oil; usually 1 drop of oil at each oiling point is sufficient.

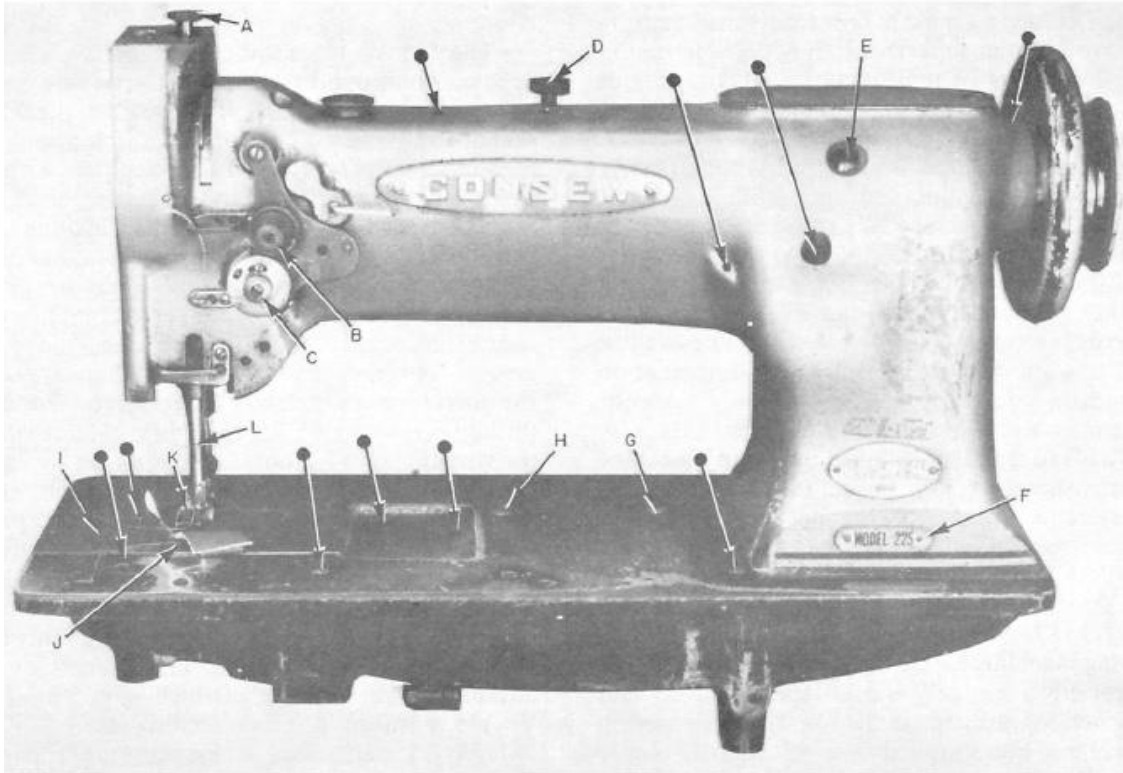

Figure 1: Front view showing oiling points (Consew 225 shown)

- | | |
|--|-----------------------------------|
| A. Vibrating presser bar thumbscrew | G. Hook-driving shaft lock stud |
| B. Tension thumb nut | H. Feed regulating stud (plunger) |
| C. Thread controller stud thumb nut | I. Bed slide |
| D. Presser bar spring regulation screw | J. Throat plate |
| E. Feed indicator disk | K. Presser foot |
| F. Model number | L. Needle-bar |

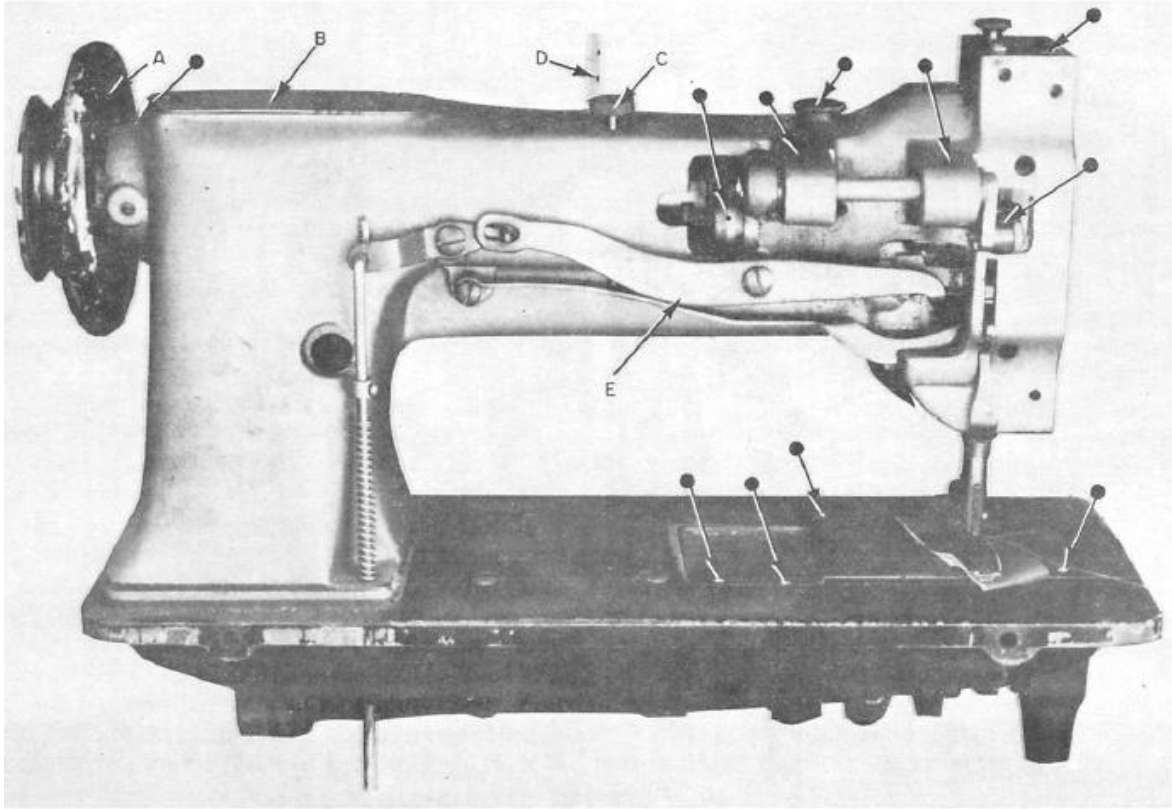

Figure 2: Rear view showing oiling points (Consew 225)

A. Balance wheel

B. Arm cap

C. Presser bar spring regulating screw

D. Thread post

E. Knee lift linkage

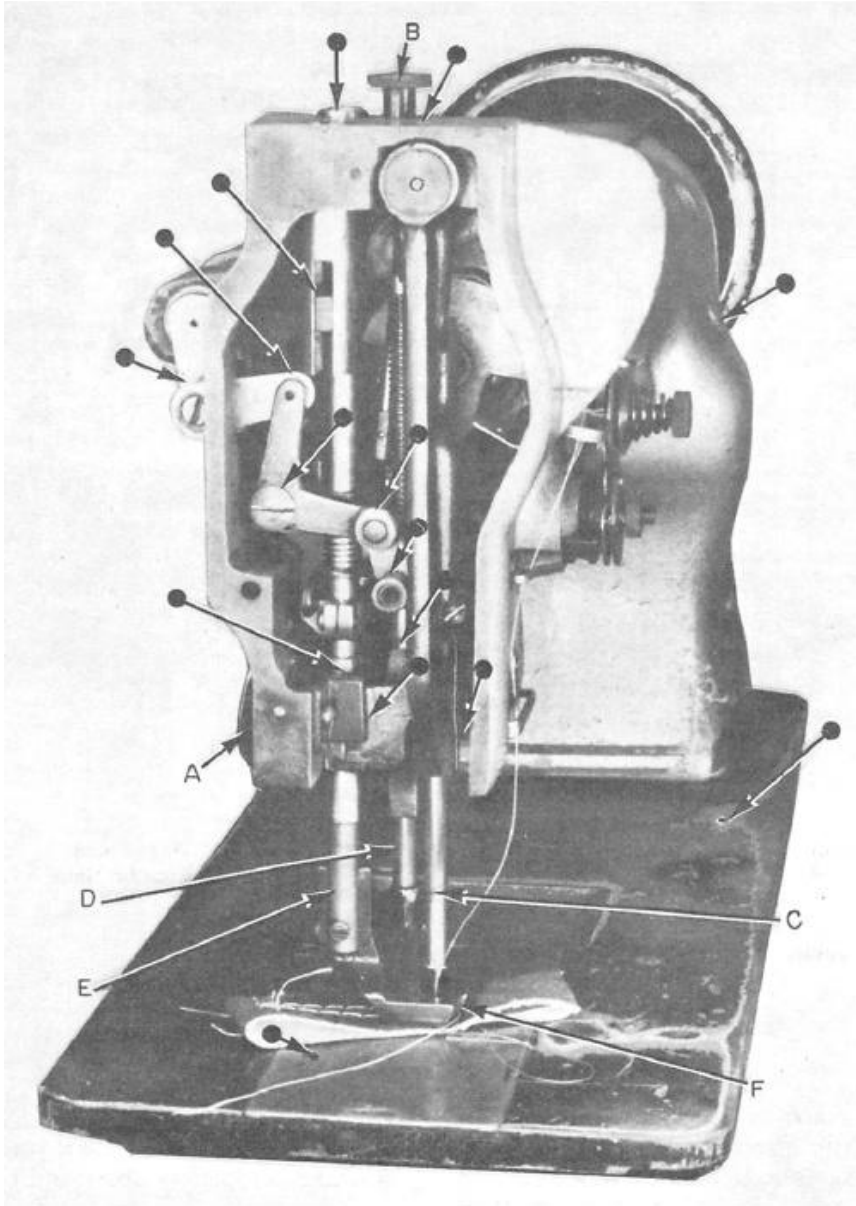

Figure 3: Side view showing oiling points (Consew 225)

- | | |
|-------------------------------------|--------------------------|
| A. Hand lift for presser foot | D. Vibrating presser bar |
| B. Vibrating presser bar thumbscrew | E. Presser bar |
| C. Needle-bar | F. Presser foot |

TIMING THE 111W155 MACHINE

Timing is the most important step when working on any sewing machine. The timing and adjustment section is presented as if the machine is being taken completely apart and reassembled.

Timing the arm shaft with the hook drive shaft

To perform this timing step, must tilt the sewing machine back on its hinges. Turn the balance wheel toward the operator until the thread take-up lever reaches its highest point. Place the fingers of the left hand on top of the thread take-up lever and turning the balance wheel with the right hand and feel the high point of the thread take-up lever with the fingers of the left hand. Check to ensure the arrows on the timing collar and the timing plate are aligned as shown in (figure 4 (B) and (C)). If the arrows don't match, remove the connection belt from the lower pulley (figure 4 [A] and [D]). Turn the lower pulley by hand until the arrow on the timing collar (figure 4 [B]) is in direct line with the arrow on the timing plate (figure 4 [C]). Replace the connection belt. This completes this timing point.

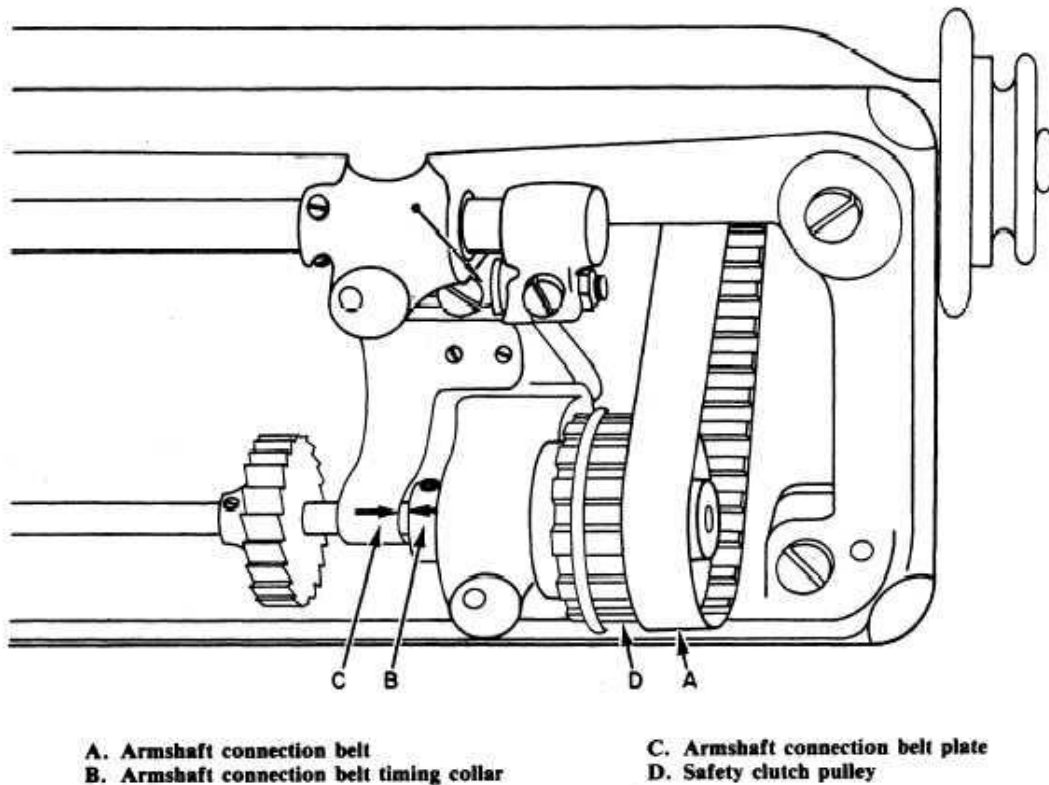

Figure 4: Timing arrows

A. Arm shaft connection link
B. Arm shaft connection belt timing collar

C. Arm shaft connection belt plate
D. Safety clutch pulley

240.71

Setting the feed dog height

Proper feed dog height is necessary to obtain proper feeding action. To set the feed dogs, proceed as follows:

- a. Turn the balance wheel toward the operator until the feed dog reaches its highest point (figure 5), and observe the relationship of the feed dog and the throat plate. If the valley between the teeth is level with the top of the throat plate, the feed dog height is correct; if the valley is not level,
- b. Loosen the feed fork screw (figure 6 [E], push the feed bar (figure 6 [F]) up or down as necessary to obtain the proper feed dog height, and tighten the screw. This completes this timing point.

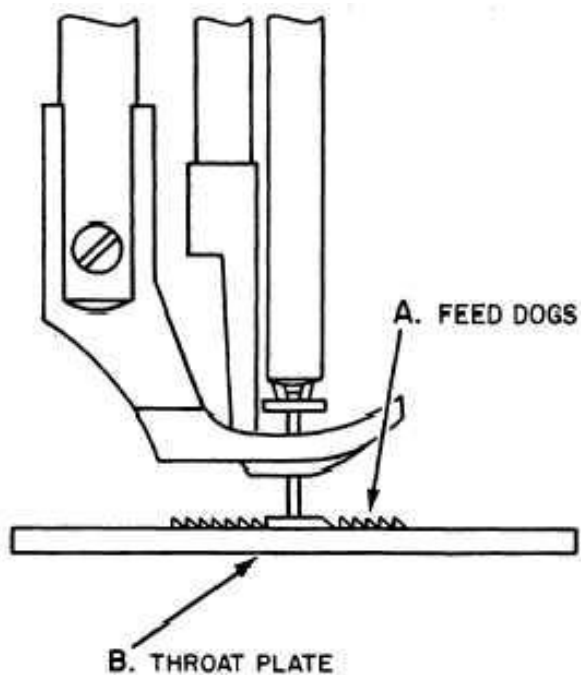

Figure 5: Feed dogs

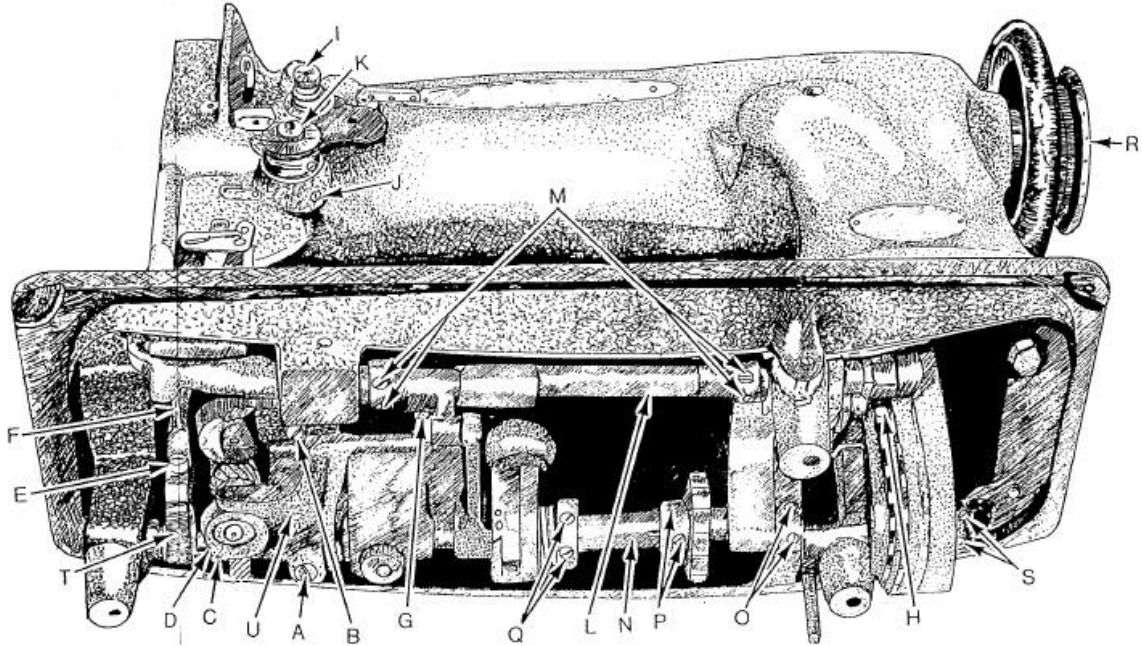

Figure 6: Feed and hook drive (Consew 225)

- | | |
|---|--|
| A. Hook saddle pinch screw | L. Feed-driving rockshaft |
| B. Hook saddle screw | M. Feed-driving rockshaft stop collars and setscrews |
| C. Hook drive gear setscrew | N. Hook-driving shaft |
| D. Hook drive spline screw | O. Hook-driving shaft bearing collar setscrews |
| E. Feed fork screw | P. Hook-driving shaft lock ratchet setscrews |
| F. Feed bar | Q. Feed-driving eccentric setscrews |
| G. Feed-driving rockshaft crank pinch screw | R. Balance wheel |
| H. Feed-driving rockshaft crank pinch screw | S. Safety clutch hook-driving shaft position collar setscrew |
| I. Thread controller assembly retaining screw | T. Feed-lifting eccentric |
| J. Thread controller stud setscrew | U. Hook saddle assembly |
| K. Thread controller thumb nut | |

Centering the feeding action

To properly time this class of sewing machine, the feeding action must be centered before the hook is timed.

NOTE: Ensure the needle-bar rock frame hinge stud and the needle-bar rock frame guide bracket are tight to prevent the needle from wandering from side to side or fore and aft.

- a. Depress the plunger (figure 1 [H]), and turn the balance wheel toward the operator until the plunger drops; keep turning the balance wheel until it stops. This sets the maximum stitch length at 3 1/2 SPI.
- b. Turn the balance wheel toward the operator and observe the movement of the feed dogs. If the feed dogs operate properly, consider them properly centered and continue to step 2. If the feed dogs strike the front or the back of the throat plate, proceed as follows:
 - (1) Loosen the feed-driving crank pinch screw (figure 6 [G]), and push the feed dog away from the point where it strikes; then retighten the feed-driving crank pinch screw.
 - (2) Turn the balance wheel toward the operator until the needle is at its lowest point and observe the relationship of the needle and the hole in the throat plate. If the needle is near the front of the hole but not touching it, proceed to step 4. If the needle needs to be centered, proceed to step 3.
 - (3) If the needle and throat hole are not properly aligned, loosen the needle-bar rock frame rockshaft connection crank pinch screw (figure 7 [A], table 4-2, foldout at the end of this chapter) and align the needle-bar in the hole of the throat plate; then retighten the screw.
 - (4) Turn the balance wheel toward the operator and observe the operation of the alternating pressers. If the front foot does not strike the back foot, then the feeding action is centered.

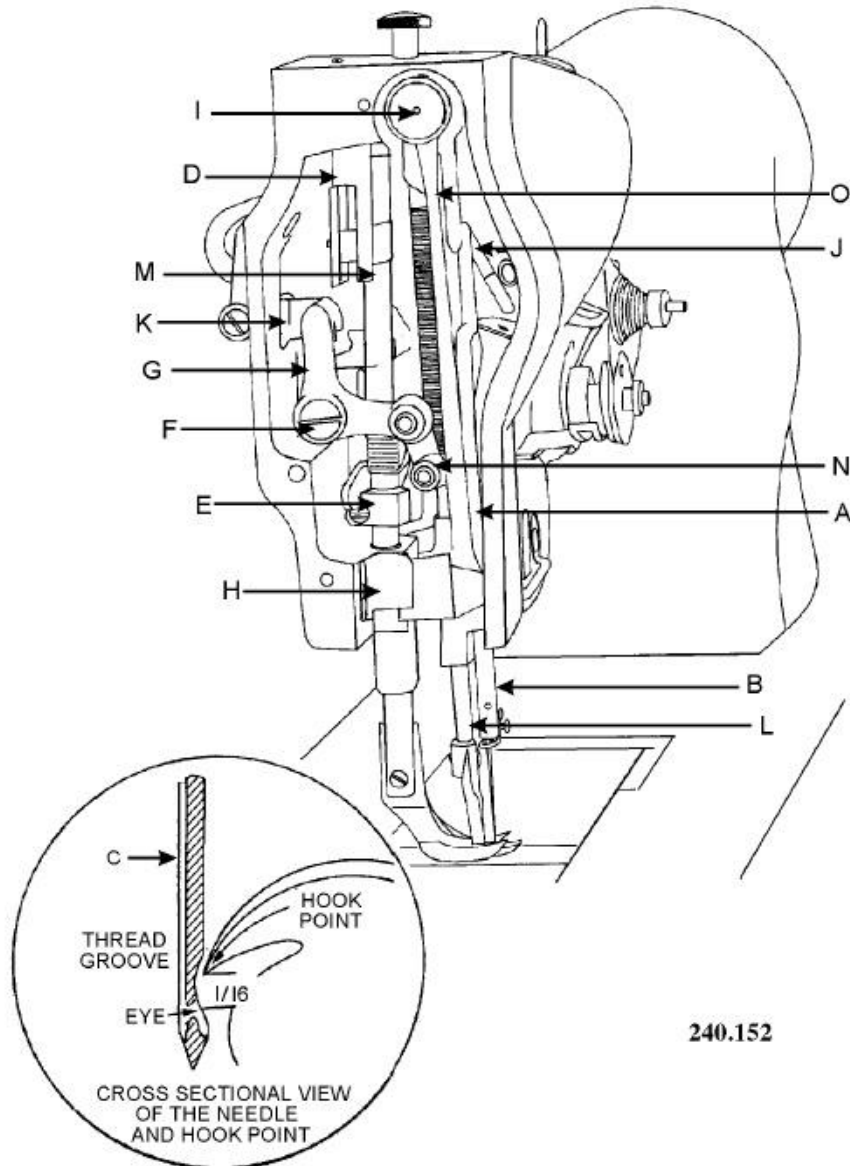

Figure 7: Face view (Consew 225)

- | | |
|--|--|
| <p>A. Needle-bar rock frame rockshaft connection crank pinch screw</p> <p>B. Needle-bar</p> <p>C. Needle-bar position height</p> <p>D. Presser bar position guide</p> <p>F. Presser-lifting bell crank retaining screw</p> <p>G. Presser lifting bell crank</p> <p>H. Needle-bar rock frame position bracket</p> | <p>I. Needle-bar rock frame hinge stud</p> <p>J. Needle-bar connecting link</p> <p>K. Presser bar guide lever</p> <p>L. Vibrating presser bar</p> <p>M. Presser bar</p> <p>N. Vibrating presser bar connecting link</p> <p>O. Needle rock frame assembly</p> |
|--|--|

Timing the hook and the needle-bar

In this timing sequence, we will consider that the machine has no timing marks on the needle-bar.

- a. Remove the throat plate, the feed dog, and the presser feet.
- b. Turn the balance wheel toward the operator until the needle is raised three-sixteenths of an inch from its lowest point.

If the point of the hook is in line with the center of the needle, one-sixteenth of an inch above the eye of the needle, and as near to the needle as possible without touching it, then the hook and needle-bar can be considered to be in time. If not, proceed to the following steps:

- (1) Loosen the pinch screw (figure 7 [A]) and move the needle-bar (figure 7 [B]) to obtain the proper height, as shown in figure 7 (C); then retighten the needle-bar clamp pinch screw.
- (2) Tilt the sewing machine back; loosen the hook saddle pinch screw (figure 6 [A]), the hook saddle adjusting screw (figure 6 [B]), and the hook drive gear setscrews and spline screws (figure 6 [C] and [D]).
- (3) Move the hook saddle (figure 6 [U]) to the right and the hook drive gear to the left until they are disengaged.
- (4) Turn the balance wheel toward the operator until the needle is raised three-sixteenths of an inch from its lowest point.
- (5) With the point of the hook in the 7 o'clock position, engage the hook pinion gear and the hook drive gear to align the hook point with the needle. As the hook is engaged, it will rotate clockwise, advancing toward the needle until the hook point is centered on the needle. The hook point should be as near as possible to the needle without touching it.

NOTE: The hook guard may be out of adjustment and prevent the hook from being adjusted close enough to the needle; if this is the case, bend the hook guard out of the way enough to allow proper adjustment. See step 8.

- (6) Tighten the hook saddle pinch screw and the hook drive gear setscrews and spline screws.
- (7) Turn the balance wheel toward the operator to ensure the hook does not strike the needle.
- (8) The hook guard prevents the sewing hook from striking the needle. Adjust the hook guard (figure 8 [A]) by bending it until it is at least as near the needle as the hook point, but does not push the needle.
- (9) Install the feed dog, the throat plate, and the presser feet.

NOTE: Ensure the bobbin-case lug (figure 9 [A]) is properly engaged in its opening in the bottom of the throat plate (figure 9 [B]).

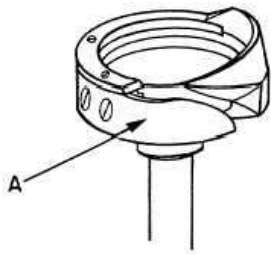

240.153

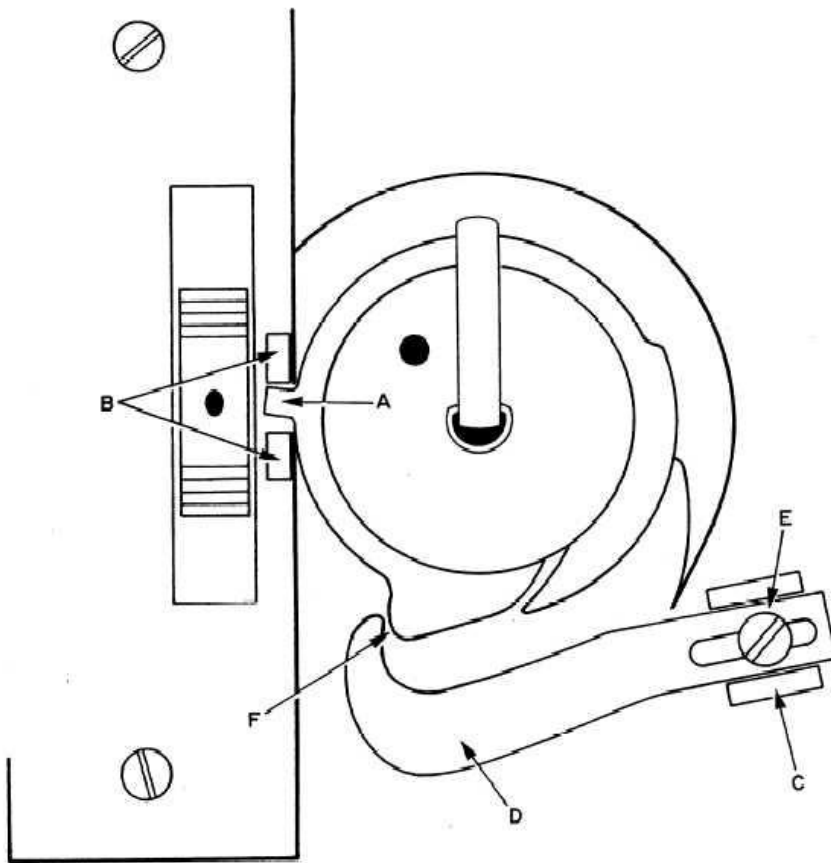

250.154

Figure 8: Sew hook (above)

Figure 9: Bobbin case area (below)

Timing the presser-lifting eccentric

The presser-lifting eccentric controls the feeding motion provided by the alternating pressers.

If the presser-lifting eccentric is not, properly timed, it can cause the machine to feed backward or prevent the machine from making the full stitch length.

The maximum stitch length of 3 1/2 SPI should be set while making the following adjustments:

- a. Turn the balance wheel toward the operator and observe the action of the feed dogs and the front presser. They should meet at the
- a. throat plate height and travel aft together; if they do not, continue to step b.
- b. Turn the balance wheel and loosen the two setscrews (figure 10B [C] and figure 10 [A]) on the presser-lifting eccentric.
- c. Hold the eccentric to prevent it from turning; then turn the balance wheel a small amount toward the operator and tighten one of the setscrews.
- d. Repeat steps b and c until the front foot meets the feed dog at the throat plate height as the balance wheel is turned toward the operator.
- e. Ensure both setscrews are tight.

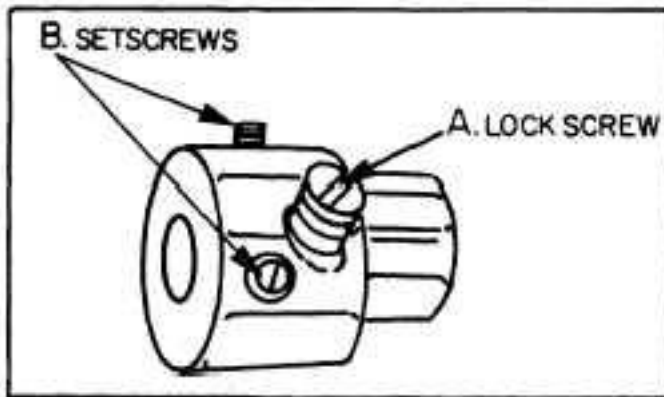

240.155

Figure 10 A: Presser-lifting eccentric connection link

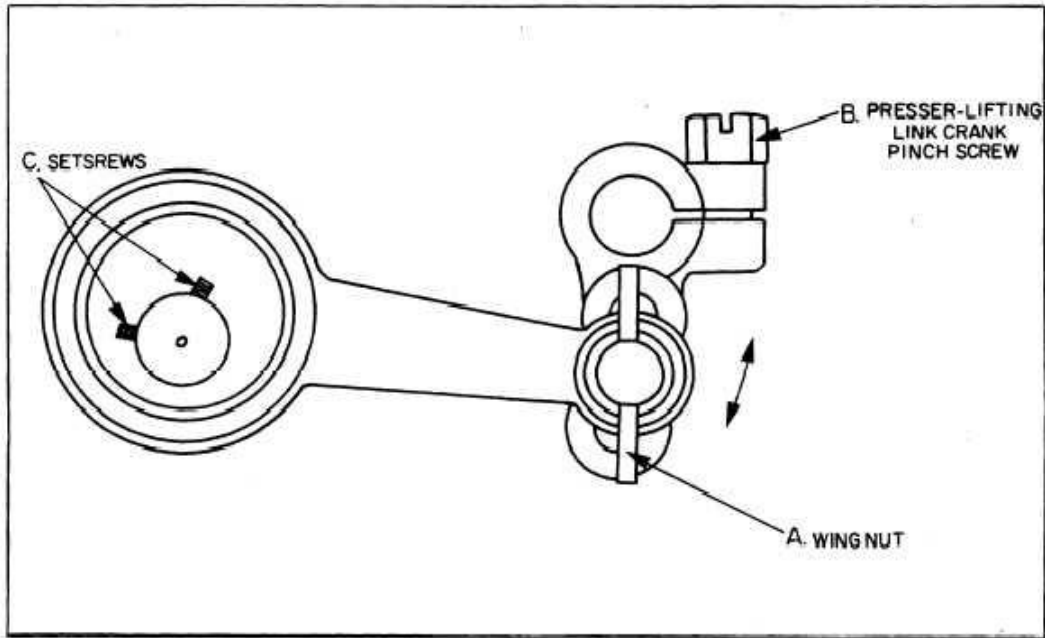

Figure 10 B: Presser-lifting eccentric

ADJUSTMENTS

For the sewing machine to operate smoothly and to make a proper locking stitch, make some minor adjustments must be made. Even though the machine is in time, a single part that is out of adjustment can cause the sewing machine to skip stitches, break thread, fail to feed the material, or make loose stitches.

Adjusting the bobbin-case opener

As the hook rotates clockwise, friction on the bobbin-case opener causes the position lug (figure 9 [A]) to press against the back of its opening. The bobbin-case opener moves the bobbin case counterclockwise to allow the thread to pass around the bobbin-case-opener lug. If the opener is adjusted too tight, damage to many parts may occur; and if the opener is not set tight enough, extreme upper thread tension may be necessary to lock the stitch properly. Adjusting the bobbin-case opener is accomplished as follows:

- a. Turn the balance wheel toward the operator until the bobbin-case-opener lever (figure 9 [C]) moves as far to the right as possible.
- b. If the bobbin-case opener (figure 9 [D]) has been removed, reinstall it at this time. Do not tighten the adjusting screw (figure 9 [E]) at this time.
- c. Place two thicknesses of paper, as a gauge, between the tip of the bobbin-case opener and its projection on the bobbin case.

- d. Move the bobbin-case opener right or left as necessary to cause the bobbin case to move as far to the right as possible without binding.
- e. Tighten the bobbin-case-opener adjusting screw.
- f. Turn the balance wheel toward the operator and observe the operation of the bobbin case and its opener. Ensure no binds are present and that the bobbin case is pulled counterclockwise as far as possible with each rotation of the hook.

Adjusting the total relative lift of the alternating pressers

The total relative lift of the alternating pressers referred to here is that the feet lift one-half inch at total lift. Maximum lift of the alternating pressers is set to sew on heavier goods. There are two types of adjustments, and either type may be found on a given machine. The first type of alternating presser (figure 10A) is usually found on earlier sewing machines, while the second type of alternating presser (figure 10B) seems to be in current manufacture.

- a. Adjusting the first type of alternating presser is accomplished as follows:

- (1) Turn the balance wheel toward the operator until the presser-lifting eccentric lock screw (figure 10A [A]) is visible inside the opening at the back of the arm of the machine. (See figure 11 [A], table 4-3, foldout at end of this chapter.)

NOTE: Figure 10A shows two setscrews (B). They are used to hold the presser lifting eccentric in place on the feed-driving rockshaft. The adjusting screw is not visible in this figure.

- (2) Loosen the lock screw and turn the balance wheel until the adjusting screw is visible in the opening in the back of the arm. (See figure 11 [A].)
- (3) Turn the adjusting screw counterclockwise to obtain maximum total lift of the pressers.
- (4) Turn the balance wheel toward the operator until the lock screw is visible in the opening in the back of the arm and retighten the lock screw.

- b. Adjusting the second type of alternating presser is accomplished as follows:

- (1) Loosen the presser-lifting eccentric adjusting wing nut (figure 10B [A]).
- (2) Move the assembly up to decrease the lift or down to increase the total lift of the alternating pressers.
- (3) Tighten the wing nut.

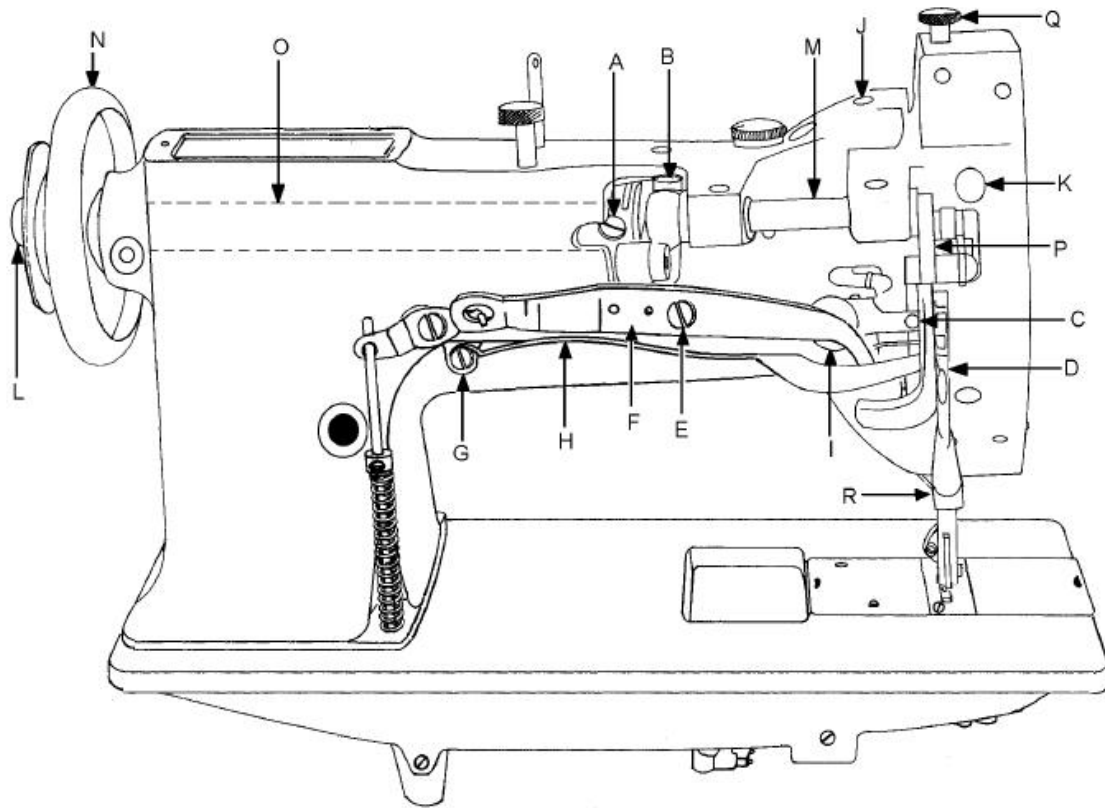

Figure 11: Rear view

- | | |
|--|--|
| A. Presser-lifting eccentric screws | J. Needle-bar connecting link oil guard |
| B. Presser-lifting link crank pinch screw | K. Presser bar guide lever pinch screw |
| C. Presser bar lifting bracket pinch screw | L. Balance wheel adjusting screw |
| D. Lifting screw | M. Presser-lifting rockshaft |
| E. Knee lifter lifting lever hinge screw | N. Balance wheel |
| F. Knee lifter lifting lever | O. Arm shaft |
| G. Presser bar spring-support screw | P. Presser |
| H. Presser bar spring | Q. Vibrating presser foot tension spring adjustment thumbscrew |
| I. Presser bar lifting releasing lever bracket guide screw | R. Vibrating presser bar |

Adjusting the relative lift of the alternating pressers

The alternating presser feet should each lift to approximately the same height. Do not confuse relative lift with total lift. Here we are adjusting the presser feet to lift to approximately the same height. Adjusting the relative lift of the alternating pressers is accomplished as follows:

- a. Turn the balance wheel toward the operator and observe the action of the alternating pressers. If they do not lift equally, proceed to step b.
- b. Turn the balance wheel until the foot that lifts too high is just above the throat plate.
- c. Loosen the presser-lifting link crank pinch screw (figure 11 [B]). The foot should snap down; if it does not, push it down.
- d. Tighten the presser-lifting link crank pinch screw.
 - e. Repeat step a. If necessary repeat steps b through d until the feet lift to the same height.

Adjusting the lifting linkage of the alternating pressers

To set the lifting linkage, loosen the lifting crank pinch screw (figure 11 [B]) and the presser bar lifting bracket pinch screw (figure 11 [C]). Turn the balance wheel toward the operator until the feed dogs rise to meet the forward presser foot at the top of the throat plate. Press the presser bar lifting bracket down to the hand-lifting lever (figure 11 [D]). Tighten the presser bar lifting bracket pinch screw (figure 11 [C]) and the lifting crank pinch screw (figure 11 [B]).

Adjusting the upper thread-tension-releasing lever

The upper thread-tension release allows the goods to be removed without the needle thread breaking.

- a. Lift the presser-lifting lever and observe the thread tension disk. It should separate to release the thread. If not, proceed as follows:
- b. Remove the thread controller assembly from the machine as follows:
 - (1) Remove the thread controller assembly retaining screw (figure 6 [1]).
 - (2) Loosen the thread controller stud setscrew (figure 6 [J]).
 - (3) Pull the thread controller assembly away from the machine.
- c. Bend the thread-releasing lever (figure 12 [B]) away from the thread controller assembly to increase the amount of the release and toward the plate to decrease the tension as needed.
- d. Reattach the assembly to the machine and observe the operation. Repeat steps a through d if necessary.

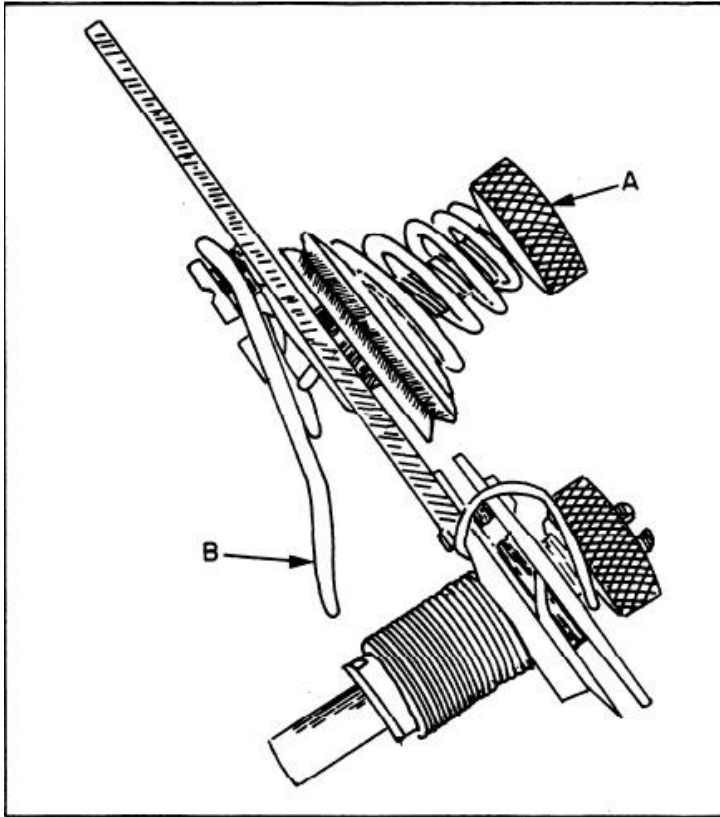

Figure 12: Upper thread unit

Setting the feed indicator disk

Loosen the setscrew in the feed indicator disk (figure 1 [E]) so that it spins on the arm shaft. Depress the feed indicator plunger and turn the balance wheel toward the operator until it drops; keep turning the balance wheel until it stops. The feed-driving eccentric is now set at 3 1/2 SPI.

NOTE: With the plunger engaged, turning the balance wheel toward the operator decreases the SPI, and turning the balance wheel away increases the SPI.

The ideal setting for the indicator disk on the sewing machine is 8 SPI. Engage the plunger and turning the balance wheel approximately one-fourth of a turn away from the operator. Release the plunger, make several inches of stitches on a piece of paper, and count the total number of stitches per inch. Depress the plunger and slowly turn the balance wheel toward the operator until the plunger drops.

- Stop.
- Release the plunger and the balance wheel.
- Now turn the feed indicator disk (figure 1 [E]) on the arm shaft until 8 shows in the window on the up-rise of the machine.
- Tighten the setscrew in the feed indicator disk.

Setting the thread controller spring

The thread controller spring prevents the needle from piercing the thread. It takes the slack out of the needle thread until the point of the needle enters the material. To properly set the tension on the thread controller spring, first loosen the thread controller stud setscrew on the tension stud (figure 6 [J]). Turn the tension stud counterclockwise for more tension or clockwise for less tension.

A properly adjusted controller spring rests on the thread controller spring stop as the point of the needle enters the material. This action releases all tension on the needle thread.

Setting the controller spring stop

It might be necessary to make an adjustment to the controller spring stop to allow the thread controller spring to operate properly. This is a very simple adjustment. Loosening the tension stud screw, shown in figure 6 (I), and raise the stop for less action or lower it for more action.

Adjusting the thread tension

The thread tension will be the last adjustment required. In most cases, make the adjustment by turning the thumbnut (figure 12 [A]) on the needle thread tension disk.

If the stitch is locking on top of the material, turn the nut counter clockwise. This loosens the upper thread tension causing the bobbin tension to draw the stitch into the material. A clockwise turn will tighten the upper thread, thus drawing up any stitch that may be locking below the material.

If the thread tension disk cannot adjust the tension, adjust the bobbin tension. To do this, tighten or loosen the small screw nearest the center of the spring. This completes all the necessary timing and adjusting on the 111W155 sewing machine. If there is still a problem, refer to the troubleshooting portion of this chapter.

TROUBLESHOOTING

While making adjustments or timing the sewing machine, use the troubleshooting chart to help locate and correct most problems. If the sewing machine is binding (hard to turn), locating the problem easily. First check the feeding action. Then set the machine on zero feed and remove the throat plate. Turn the machine by hand. If the bind is still present, remove the arm shaft connection belt. If the bind is located in the hook-driving shaft, the machine will turn freely. Turn the balance wheel by hand. If the bind is located in the arm shaft, the bind will still be present.

Trouble	Probable Cause	Remedy
Thread breakage	Improper threading	Rethread
	Thread controller	Adjust spring tension or spring stop
	Right twist thread	
	Hook point piercing needle thread	Adjust thread controller spring stop
	Needle eye too small	Select larger size
	Burr on needle point	Replace needle
	Too much tension	Adjust tension springs
	Thread unwinding improperly	Adjust stand or spool
	Thread breaks when clearing work	Adjust tension release. Thread take-up lever not at highest point
	Hook out of time (retarded)	Retime
Skipped stitches	Needle bar improperly set	Reset
	Needle not completely inserted	Insert correctly
	Needle incorrectly aligned	Insert correctly
	Needle threaded from wrong side	Rethread needle
	Thread too large for needle eye	Select correct needle or thread
	Presser bar out of adjustment	Adjust presser bar
	Hook too far from needle	Reset hook saddle
	Hook out of time	Retime
Thread jamming under throat plate	Operating machine without material	Unthread when running without fabric
	Failure to hold free ends of thread for first stitches	Maintain pressure on free ends of thread
	Needle thread not between tension disks	Thread disk
Upper thread looping under material	Feed-driving eccentric improperly adjusted	Adjust eccentric
	No upper thread tension	Adjust or replace thread in tension disk

Trouble	Probable Cause	Remedy
Failure to feed	Feed-driving crank loose	Tighten pinch screw
Stitches not in line	Insufficient presser foot pressure	Add spring tension
	Presser bar improperly set	Adjust presser bar
	Feed dogs too low	Set height to one full tooth
Material damaged by scuffing	Presser foot pressure too great	Reduce pressure
	Feed dogs too high	Set one tooth less
	Ridged-bottom foot	Change to smooth-bottomed foot
Sluggish operation	Improper lubrication or accumulation of material	Clean with solvent and lubricate
Failure to make a stitch	Needle in backwards	Install correctly
	Needle threaded from wrong side	Thread correctly
	Wrong needle variety	Change to correct variety
	Bent needle	Change needle
	Needle not all the way into needle bar	Insert correctly
	Needle bar out of adjustment	Adjust needle bar
	Shuttle driver pin sheared	Replace pin
	Shuttle too far from needle	Shim shuttle closer to needle
	Safety clutch disengaged	
	Thread too large for needle	Select larger size
Feed failure	Arm shaft not in time with sewing hook driving shaft	Retime by take-up lever and timing plate (timing collar spline screw must be in spline)
	Feed lifting cam fork inverted	Install properly
	Feed-driving crank pinch screw loose	Re-center feed and tighten pinch screw
	Feed-driving eccentric out of spline	Reset
	Feed dogs set too high	Reset
	Set at negative feed	Set for stitching
Feeding backwards	Feed lifting cam out of spline	Reset in spline
	Feed-driving eccentric out of spline	Reset in spline
	Presser-lifting eccentric out of time	Time eccentric
	Timing collar out of spline	Reset in spline and retime machine
Stitches not in line	Insufficient presser foot pressure	Add spring pressure
	Feed dogs too low	Set height to one full tooth

Trouble	Probable Cause	Remedy
Thread jamming	Operating machine without material	Unthread when running without fabric
	Failure to hold free ends of thread for first stitches	Maintain pressure
	Bobbin-case opener incorrectly set	Readjust opener
	Needle thread not between disks	Thread disks
	Hook too high	Lower hook
	Turning balance wheel backwards with needle threaded	Remove jam
	Thread, dirt, lint under bobbin case	Remove case, clean and replace
Not stitching as indicated	Indicating disk loose	Reset and tighten
	Indicating disk incorrectly set	Reset and tighten
	Automatically changing stitches	Adjust feed eccentric gib
Binds	Bobbin-case opener set too close	Set to allow thread passage around bobbin-case lug
	Arm shaft friction washer missing	Install friction washer
	Balance wheel improperly set for tolerance	Tighten adjusting screw, back of one-quarter turn, tap with mallet
	Needle bar too high or too low	Reset in frame
	Feed-driving connection against eccentric body	Set connection flush with frame
	Hook guard washer rubbing bobbin-case opener lever link	Replace washer. Adjust hook assembly for tolerance
	Pinion gear against saddle	Relocate on hook shaft
	Hook driving gear against saddle	Relocate to center on center line of sewing hook shaft
	Bobbin-case thread jam	Remove case, clear and reinstall
	Feed dogs against throat plate	Adjust to proper height. Adjust to center of throat plate
	Feed bar hinge stud screw	Adjust for proper operating tolerance
	Wrong bed slide over sewing hook	Put recessed slide over sewing hook
Alternating pressers out of adjustment	Reset	

DISASSEMBLY AND REASSEMBLY OF THE 111W155 SEWING MACHINE

You probably will never need to take the 111W155 class sewing machine completely apart, but you may need to replace some parts. Therefore, you need to know the procedures for disassembling and reassembling the 111W155 sewing machine.

The following are some helpful hints that you should remember while working on disassembly and reassembly of any sewing machine:

- All sewing machine screws have a *case-hardened surface, which must be removed by grinding* should it become necessary to use an easy-out to remove the screw.
- Using grinding compound is recommended when you are replacing parts that attach to a shaft. Place a small amount of grinding compound on the shaft and rotate the part on the shaft until it moves freely. (Remove all grinding compound before you reassemble the parts.)
- Oiling is a must in the reassembly of parts. A generous amount of 10W mineral oil is justified when you are replacing parts.
- There is one screw (thread take-up lever retaining screw) on the drop-feed type of sewing machine that has a left-hand thread. It is found in the face of the machine. This screw is removed by turning it clockwise.

DISASSEMBLY

In this section we discuss the purpose of each part of the 111W155 sewing machine and the disassembly and reassembly of each part.

Before disassembling any sewing machine, you should select and clean an area that will allow you to work on your project with a minimum of interruptions. Select your tools, cleaning solvents, and a parts breakdown list; then you are ready to begin your project.

Arm Cap

The arm cap (figure 2 [B]) permits inspection of the mechanism of the arm. The arm mechanism is exposed when the arm cap is moved to one side or the other. Remove the arm cap by unscrewing the holding screw and spring washer that attach it to the machine arm; then lift the arm cap from the machine.

Faceplate

The faceplate (figure 2 [F]) permits inspection and minor adjustment of the parts in the machine face. The mechanism of the machine face is exposed when the faceplate is moved to one side or the other. Remove the faceplate by removing the

thumbscrew at the top of the plate; then move the plate slightly to the left to clear the metal projection at the lower left corner and lift the faceplate from the machine.

Knee Lifter Lifting Lever Hinge Screw

The knee lifter lifting lever hinge screw (figure 11 [E]) acts as a hinging point for the knee lifter lifting lever. It is removed from the machine by unscrewing it.

Knee Lifter Lifting Lever

The knee lifter lifting lever (figure 11 [F]) acts as an extending arm that attaches the presser bar lifting releasing lever bracket to the knee lifter lifting lever. It carries the motion from the knee lifter lifting lever to the presser bar lifting releasing lever bracket. Remove the knee lifter lifting lever by grasping and moving it outward from the machine.

Presser Bar Spring Support Screw

The presser bar spring-support screw (figure 11 [G]) acts as a suspension point for the presser bar spring. The screw is loosened approximately one-fourth of- an inch to allow for the removal of the presser bar spring. *Do not remove the presser bar spring-support screw from the machine.*

Presser Bar Spring

The presser bar spring (figure 11 [H]) applies a constant pressure to the presser bar. To remove the presser bar spring from the machine, lower the presser feet and then grasp the underside of the spring as near the support screw as possible with two fingers of one hand over two fingers of the other hand. Now slide the spring outward to the head of the support screw, rolling the spring up and out of the machine.

Presser Bar Lifting Releasing Lever Bracket Guide Screw

The presser bar lifting releasing lever bracket guide screw, (figure 11 [I]) acts as a track and guide for the presser bar lifting releasing lever bracket. Remove the presser bar lifting releasing lever bracket guide screw by unscrewing it from the machine.

Presser Bar Position Guide

The presser bar position guide (figure 7 [D]) acts as a track to control the presser bar position guide lever. To remove the presser bar position guide, you should loosen (six turns) the spline screw on the rear side nearest the face of the machine and push the guide through the recess at the top of the machine head.

Presser Bar Position Guide Lever

The presser bar position guide lever is used to align the presser foot, and it operates in the slot of the presser bar guide.

NOTE: The presser bar position guide does not screw out. Loosen the pinch screw on the presser bar position guide lever (figure 11 [K]) by inserting the screwdriver into the opening on the rear side of the machine head. This is necessary to allow movement of the presser bar for the removal of attached parts.

Alternating Presser Foot

The alternating presser foot is the rear presser foot and holds the material in place while the needle and front presser foot move forward making another bight. To remove the rear presser foot, you unscrew the presser foot position screw on the left side of the presser bar. Raise the presser bar to its highest position and remove the foot from the rear.

Presser Bar Spring Bracket

The presser bar spring bracket (figure 7 [E]) transfers the tension from the presser bar spring to the presser bar. To loosen the presser bar spring bracket from the presser bar, insert the screwdriver through the lower opening provided in the back of the face of the machine. Loosen the presser bar lifting bracket pinch screw (figure 11 [C]). Remove the presser bar lifting bell crank retaining screw and lifting bell crank (figure 7 [F] and [G]). Now remove the presser bar (figure 7 [M]) in a slow upward motion.

Presser-Lifting Bell Crank

The presser-lifting bell crank alternately applies lift to the presser feet. Remove the presser-lifting bell crank retaining screw (figure 7 [F]) and then extract the bell crank (figure 7 [G]) from the machine.

Presser Bar Lifting Bracket

The presser bar lifting bracket is alternately a hinge point and lifting point for the two presser bars. It is also the controlling part for the presser feet while work is being inserted and removed, and it gives support to the thread tension release slide.

CAUTION

If binding should occur while you are removing the presser bar, insert a screwdriver into the lower slot of the presser bar and rotate it while applying upward motion on the presser bar.

When you remove the presser bar, the following parts will fall off: the presser bar spring bracket (figure 7 [E]), the releasing bracket, the releasing bracket spring, the lifting bracket, and the guide lever.

- Now remove the vibrating presser bar connecting link (figure 7 [N]) from the face of the machine.
- Loosen the presser-lifting link crank pinch screw (figure 11 [B]). Rotate the presser-lifting rockshaft (figure 11 [M]) away from the machine about 90 degrees. Remove the presser- lifting bell crank connection from its stud. Now remove the presser-lifting rockshaft; then remove the presser-lifting link crank (figure 11 [P]) from its connection link.

Needle-bar Rock Frame Position Bracket

The needle-bar rock frame position bracket (figure 7 [H]) holds the needle-bar rock frame in position and prevents any side-to-side play. To remove the needle-bar rock frame position bracket, you remove the holding screw and withdraw the bracket from the machine.

Tension Release Rod

The tension release lever rod releases the tension on the thread. This allows the thread to be pulled freely when you remove material from the machine. When the presser bar is lifted, the shoulder on the arm of the presser bar lifting releasing slide bracket presses the tension release rod, thereby releasing the tension on the thread. You remove the tension release rod by tilting the machine backward and allowing the rod to slide from its recess. Unscrew and remove the vibrating presser foot tension spring adjustment thumb- screw (figure 11 [Q]). At this point, you can remove the vibrating presser foot (figure 11 [R]).

Vibrating Presser Foot

The vibrating presser foot is the foremost foot. It moves fore and aft as well as up and down, and combines its actions with that of the needle and the feed dogs.

Needle-bar Rock Frame Hinge Stud

The needle-bar rock frame hinge stud (figure 7 [I]) acts as a hinging point for the needle-bar rock frame. To remove the needle-bar rock frame hinge stud, you loosen the setscrew on the top of the machine head; then you press the hinge stud out through the face of the machine.

Needle-bar Rock Frame Assembly

The needle-bar rock frame assembly (figure 7 [O]) consists of seven major parts: the needle-bar connecting stud, the needle-bar, the needle-bar rock frame, the needle-bar rock frame slide block, the vibrating presser bar, the vibrating presser bar spring, and the presser bar spring guide rod. To remove the needle-bar rock frame assembly, you grasp it and withdraw it from the face of the machine.

Needle-bar Connecting Link Oil Guard

The needle-bar connecting link oil guard (figure 11 [J]) prevents oil from being thrown through the thread take-up lever groove. To remove the needle-bar connecting link oil guard, you insert the screwdriver in the opening in the rear of the machine face, remove the holding screw and then remove the oil guard.

Take-up Lever Hinge Stud

The take-up lever hinge stud acts as a hinging point for the thread take-up lever. To remove the take-up lever hinge stud, first you loosen the setscrew located three-fourths of an inch to the right of the thread take-up lever; then you insert the screwdriver in the oil hole and push the take-up lever hinge stud out through the face of the machine.

Thread Take-up Lever

The thread take-up lever pulls the slack out of the needle thread to lock the stitch in the goods being sewn. To remove the thread take-up lever, you turn the balance wheel until the needle-bar connecting link is at its lowest position; then withdraw the thread take-up lever through the face of the machine.

Thread Take-up Lever Driving Stud

The thread take-up lever driving stud transfers power and motion from the needle-bar connecting link to the thread take-up lever. The thread take-up lever driving stud is attached to the thread take-up lever; they are removed from the machine at the same time.

Needle-bar Connecting Link

The needle-bar connecting link (figure 7 [J]) changes the rotary motion of the needle-bar crank to the vertical motion of the needle-bar. Remove the needle-bar connecting link by grasping it and then withdrawing it from the face of the machine.

Balance Wheel Adjusting Screw

The balance-wheel adjusting screw (figure 11[L]) eliminates end play in the balance wheel and arm shaft. Remove the balance wheel adjustment screw.

Balance Wheel

The balance wheel (figures 4-6 [R] and 4-11 [N]) transfers the motion and power from the one- third-horsepower electric motor to the arm shaft. To remove the balance wheel, you must first loosen the two setscrews attaching it to the arm shaft; then you withdraw it from the machine.

NOTE: The balance wheel is very fragile. Do not hit it with a hammer to remove it.

Arm Shaft Connection Belt

The arm shaft connection belt (figure 4 [A]) transfers the power and motion from the arm shaft connection belt pulley to the safety clutch pulley. To remove the arm shaft connection belt, you insert a small screwdriver along the left edge and slide the belt from the safety clutch pulley.

Arm Shaft Connection Belt Pulley Position Screw

The arm shaft connection belt pulley position screw holds the pulley in a freed position. The arm shaft connection belt pulley position screw is the larger of the two screws on the pulley. The smaller screw is a setscrew. It must be loosened but not removed from the pulley. Remove the arm shaft connection belt pulley position screw by unscrewing it.

NOTE: For machines with ball bearings, the arm shaft arm bushing setscrews are located just to the right of the connection belt pulley. They secure the arm shaft bushing to the arm shaft. These screws are not removed from the bushing; however, they must be loosened for the arm shaft to be removed.

The Presser-Lifting Eccentric

The presser-lifting eccentric supplies the lift for the alternating presser feet. Free the presser-lifting eccentric by loosening the two presser-lifting eccentric setscrews located through the opening in the rear of the arm (figure 11 [A]). You must rotate the balance wheel to loosen the second screw. Be sure the eccentric rotates freely on the shaft.

Feed Indicator Disc

The feed indicator disc shows the operator the number of stitches per inch the machine is sewing. It also allows the operator to set the machine to sew a desired number of stitches per inch. Loosen the feed indicator disc setscrew and ensure the disc will rotate freely on the shaft.

Needle-bar Crank

The needle-bar crank transfers the motion and power from the arm shaft to the needle-bar by the needle-bar driving stud. Do not remove the needle-bar crank from the arm shaft.

Needle-bar Connecting Link Stud

The needle-bar connecting link stud transfers the motion and power from the needle-bar crank to the needle-bar connecting link. Do not remove the needle-bar connecting link stud from the arm shaft.

Needle-bar Crank Friction Washer

The needle-bar crank friction washer acts as a bearing surface between the needle-bar crank and the front arm shaft bushing. In some cases the needle-bar crank friction washer remains with the machine upon removal of the arm shaft bushing. If this occurs, insert the index finger in the arm shaft recess and remove the washer.

NOTE: The operator must be especially careful when assembling the machine to be certain the needle-bar crank friction washer is returned to the arm shaft. Absence of the needle-bar crank friction washer will cause the machine to bind.

Arm Shaft

The arm shaft (figure 11 [0]) acts as a carrier for, and transfers the power and motion to, the arm shaft connection belt pulley, the feed indicator disc, the needle-bar crank friction washer, and the needle-bar crank. To remove the arm shaft, grasp it with the left hand and withdraw it from the face of the machine.

Right- and Left-Hand Bed Slide Plates

The bed slide plates allow for inspection and maintenance of the bobbin assembly. The right-hand bed slide has a cutout on the bottom side. This cutout allows the needle thread to pass over the bobbin case without jamming.

Throat Plate

The throat plate acts as a guide for the feed dog and provides a firm foundation over which the material may flow while the stitch is being made. The throat plate does not need to be removed from the machine.

Needle-bar Rock Frame Rockshaft

The needle-bar rock frame rockshaft carries the feeding motion and power from the feeding mechanism in the bed of the machine to the needle-bar rock frame. To

remove the needle-bar rock frame rockshaft, you insert the screwdriver in the opening in the rear of the upright and loosen the needle-bar rock frame rockshaft crank pinch screw. Remove the needle-bar rock frame rockshaft from the face of the machine.

Needle-bar Rock Frame Rockshaft Crank and Connection

The needle-bar rock frame rockshaft crank and connection transfers the feeding motion and power from the feed-driving rockshaft crank to the needle-bar rock frame rockshaft. To remove the needle-bar rock frame rockshaft crank and connection, you loosen the pinch screw at the feed-driving rockshaft crank (figure 6 [G]). Then you grasp the feed-driving rockshaft crank (figure 6 [H]), slide it to the right to remove it from the feed-driving rockshaft, and withdraw it from the machine. In so doing, the needle-bar rock frame rockshaft crank and connection parts are also removed. The parts removed remain as an assembly.

Feed-Driving Rockshaft Crank

The feed-driving rockshaft crank transfers the feeding motion of the feed-driving rockshaft to the needle-bar rock frame rockshaft crank and connection. The feed-driving rockshaft crank is removed simultaneously with the needle-bar rock frame rockshaft crank and connection.

Feed-Lifting Cam Fork

The feed-lifting cam fork gives the feed dog its up and down motion during the feeding operation. To remove the feed-lifting cam fork, you unscrew the feed-lifting cam fork screw (figure 6 [E]), tilt the fork toward the operator, and withdraw it.

Feed-Driving Rockshaft

The feed-driving rockshaft (figure 6 [L]) coordinates the feeding motion of the feed dog and the feeding of the needle. To remove the feed-driving rockshaft, proceed in the following manner (refer to figure 6):

- Loosen the hook saddle adjusting screw (figure 6 [B]).
- Loosen the hook saddle pinch screw (figure 6 [A]).
- Slide the hook saddle to the right as far as possible.
- Loosen the feed-driving rockshaft crank pinch screw (figure 6 [G]).
- Loosen the setscrews on each of the feed-driving rockshaft stop collars (figure 6 [M]).
- Lift the feed bar toward the operator until it reaches a stop position. Move the bar to the left until it strikes the bed of the machine. Lift the bar upward to clear the bed of the machine and continue moving it to the left until the right end of the shaft reaches the feed-driving crank; this action forces the right feed-driving

rockshaft stop collar from the rockshaft. Continue moving the rockshaft to the left until it clears the left stop collar. Withdraw the rockshaft from the machine.

Feed-Driving Rockshaft Stop Collars

The feed-driving rockshaft stop collars and setscrews (figure 6 [M]) act as retainers on each end of the feed-driving rockshaft to prevent any side-to-side play. The feed-driving rockshaft stop collars are removed in conjunction with the feed-driving rockshaft.

Feed Bar

The feed bar (figure 6 [F]) transfers the power and motion from the feed-driving rockshaft to the feed dog.

Feed Dog

The feed dog aids the needle in feeding the material to the machine. It is attached to the feed bar.

Hook-Driving Shaft and Attached Parts

The removal of the hook-driving shaft (figure 6 [N]) begins with the loosening of the attached parts, starting from the right and working to the left.

- Loosen the setscrew and the spline screw in the hook-driving shaft bearing collar. (See figure 6 [O].)
- Loosen the two setscrews in the hook-driving shaft lock ratchet. (See figure 6 [P].)

NOTE: Machines fitted with cast iron bushings instead of ball bearings will have only one spline screw.

- Loosen the spline screw and the setscrews in the feed-driving eccentric. (See figure 6 ([Q].)
- Loosen the hook saddle pinch screw (figure 6 [A]).
- Loosen the two setscrews in the hook-driving gear.
- Loosen the spline screw in the feed-lifting eccentric (figure 6 [T]).

NOTE: After you loosen the spline screw and the setscrews, each part must rotate freely on the shaft.

Safety Clutch Pulley

The purpose of the safety clutch pulley (figure 4 [D]) is twofold. First, it is used to transfer the power and motion from the arm shaft connection belt to the hook-

driving shaft; second, it protects the hook from being damaged by disengaging when the hook is jammed. To remove the safety clutch pulley, you loosen the two setscrews (figure 6 [S]) that attach the safety clutch pulley to the hook-driving shaft and withdraw the pulley.

Feed-Lifting Eccentric

The feed-lifting eccentric (figure 6 [T]) supplies a lifting motion to the feed-lifting eccentric fork. Remove the feed-lifting eccentric by moving the hook-driving shaft to the right until it clears the feed-lifting eccentric, thus allowing the eccentric to drop from the shaft.

Hook-Driving Gear

The hook-driving gear converts the longitudinal motion in the hook-driving shaft to the horizontal motion on the sewing hook. Remove the hook-driving gear by moving the hook-driving shaft to the right until it clears the hook-driving gear, thus allowing the hook-driving gear to drop from the shaft.

Feed-Driving Eccentric

The feed-driving eccentric sets up the motion and controls the feeding mechanism of the sewing machine. Remove the feed-driving eccentric by moving the hook-driving shaft to the right until it clears the feed-driving eccentric, thus allowing it to drop from the shaft.

Feed-Driving Connection

The feed-driving connection carries the feeding motion to the feed-driving crank. Remove the feed-driving connection simultaneously with the feed-driving eccentric. Remove the connection from the eccentric by withdrawing it from the eccentric.

Feed-Driving Crank

The feed-driving crank transfers the feeding motion from the feed-driving connection to the feed-driving rockshaft. The feed-driving crank is attached to the feed-driving connection and is removed from the sewing machine when you remove the feed-driving connection.

Hook-Driving Shaft Lock Ratchet

The hook-driving shaft lock ratchet locks the hook-driving shaft in position while you set the safety clutch. Remove the hook-driving shaft lock ratchet by moving the hook-driving shaft to the right until it clears the hook-driving shaft lock ratchet, thus allowing it to drop from the shaft.

Arm Shaft Connection Belt Timing Collar and Hook-Driving Shaft Ball-Bearing Collar

The arm shaft connection belt timing collar and the hook-driving shaft ball-bearing collar are the initial timing points on the machine. ***Do not remove these parts from the machine.*** In machines fitted with cast iron bushings, the timing collar will fall off as the shaft is withdrawn.

Hook-Driving Shaft

The hook-driving shaft (figure 6 [N]) transfers power and motion to the units attached to it. To remove the hook-driving shaft, you grasp it and withdraw it to the right.

Bobbin-Case Opener

The bobbin-case opener (figure 9 [D]) acts as a lever to pull the bobbin case back from the throat plate. It allows the needle thread to pass between the bobbin case and the throat plate. To remove the bobbin-case opener, you unscrew the adjusting screw (figure 9 [E]) and lift it from the hook saddle assembly.

Hook Saddle Screw

The hook saddle screw (figure 6 [B]) holds the hook saddle assembly in place. Unscrew the hook saddle screw to remove it.

Hook Saddle Assembly

The hook saddle assembly (figure 6 [U]) forms the lower half of the stitch. To remove the hook saddle assembly, unscrew the hook saddle screw and loosen the hook saddle pinch screw (figure 6 [A]). Draw the hook saddle assembly slightly toward the operator, slide it to the left until it clears the center hook-driving shaft bushing, and withdraw it from the machine. This completes the disassembly of the sewing machine.

REASSEMBLY

Before reassembling the sewing machine, you will need some grinding compound to smooth parts that may have surface rust or small burrs.

A small amount of grinding compound on the surface is sufficient. Rotate the two parts until they move freely. You will also need some 10W mineral oil to lubricate all moving parts. After you accomplish these tasks, proceed as follows to reassemble the sewing machine.

Hook Saddle Assembly

To replace the hook saddle assembly, hold it in an upright position with the saddle clamp facing the bed of the machine; then place the saddle clamp on the edge of the center hook- driving shaft bushing. Swing the hook saddle assembly toward the bed of the machine and slide it to the right and into place in the opening in the casting.

Hook Saddle Screw

With the hook saddle assembly as far to the right as it will go, replace the hook saddle screw and tighten it.

Bobbin-Case Opener

Lift the machine to the upright position. Replace the bobbin-case opener so that the curved end points toward the bobbin case. Replace the bobbin-case opener adjusting screw and tighten it.

Hook-Driving Shaft

Tilt the machine forward. In replacing the hook-driving shaft, you should note that it has five splined grooves. One of the splined grooves is located at one end of the shaft. Insert the end without a splined groove into the right hook- driving shaft bearing.

Hook-Driving Shaft Lock Ratchet

As the hook-driving shaft is pushed toward the left, or face, of the machine, replace the hook- driving shaft lock ratchet so that the flange with the setscrews faces the left of the machine.

Feed-Driving Connection and Feed-Driving Crank

Hold the feed-driving eccentric with the flange and spring to the right; then place the feed-driving connection, with the feed-driving crank attached, over the cam on the feed-driving eccentric. Be sure the oiling felt faces upward and the crank is toward the operator.

Feed-Driving Eccentric

Holding the feed-driving eccentric in the same manner as stated above, you replace it on the hook-driving shaft.

Hook-Driving Gear

Push the hook-driving shaft through the center hook-driving shaft bushing. Replace the hook- driving gear so that the flange with the setscrews is facing toward the left.

Feed-Lifting Eccentric

Place the feed-lifting eccentric on the hook- driving shaft and slide the hook-driving shaft into the front hook-driving shaft bushing, leaving approximately 2 inches of the hook-driving shaft extended to the right of the rear hook-driving shaft bushing.

Safety Clutch Pulley

Replace the safety clutch pulley so that the safety clutch hook-driving shaft stop collar, with the screws in it, is flush with the right end of the hook-driving shaft. Turn the safety clutch pulley until the spline screw marked with the letter *S* is positioned over the spline in the hook-driving shaft. Tighten the spline screw and the setscrew.

Feed-Driving Rockshaft

The cylinder end of the feed-driving rockshaft is placed from the left into the feed-driving rockshaft bushing. The flat side of the feed- driving rockshaft stop collar is placed flush with the bushing, and the rockshaft is moved forward to enter the stop collar. The feed-driving crank is placed next to the stop collar, and the rockshaft is moved forward to enter the crank. The remaining stop collar is placed on the rockshaft with the flat side to the right. The rockshaft (with the base of the feed bar toward the operator) is moved through and 1 inch past the right bushing. Holding the base of the feed bar toward you, rotate the rockshaft downward toward the bed of the machine and fit the feed dog into the throat plate.

Place the feed-lifting eccentric fork over the feed-lifting eccentric and fit the base of the feed bar into the slot at the top of the feed-lifting eccentric fork. When the feed-lifting eccentric fork is in position, the rounded end of the fork will be facing you. To secure the feed-lifting eccentric fork to the feed dog, you must place the feed eccentric fork screw into the space provided and tighten it.

The feed-driving rockshaft crank is attached to the needle-bar rock frame rockshaft crank and connection. To replace it, insert the needle-bar rock frame rockshaft crank and connection with the curved portion upward and the crank hanging down into the arm through the opening in the bed of the machine. Slide the feed-driving rockshaft crank over the feed-driving rockshaft. *Do not tighten the crank.* Ensure all other screws are tight.

This completes the assembly of the parts in the bed of the machine. Now we will assemble the parts located in the arm of the machine.

Needle-bar Rock Frame Rockshaft

(At this point, the machine is placed in an upright position.) Place the needle-bar rock frame rockshaft in the lower bushing in the face of the machine. Push it through

until the end of the shaft is flush with the bushing in the arm of the machine. This may be viewed through the opening in the top of the machine arm. Place the screwdriver through the opening in the right side of the machine arm and engage the needle-bar rock frame rockshaft crank. Lift the crank with the screwdriver so that it is on line with the needle-bar rock frame rockshaft. With the left hand, push the rockshaft through the crank. *Do not tighten the crank.*

Arm Shaft

In replacing the arm shaft, be certain that the needle-bar crank friction washer is on the shaft. Insert the arm shaft in the top bushing in the face of the machine; then push it through until it can be seen through the opening located on the rear of the machine arm.

Presser-Lifting Eccentric Connection Link

Insert the larger end of the presser-lifting eccentric connection link (figure 10A) with the oil holes facing up. Slowly push the arm shaft through the arm of the machine until you can see the arm shaft at the opening on the top of the machine nearest the balance wheel.

Presser-Lifting Eccentric

Place the presser-lifting eccentric (figure 10B) onto the arm shaft with the small end toward the face of the machine. At this time, slide the presser-lifting eccentric toward the face until it goes inside the connecting link.

Feed Indicator Disc

The feed indicator disc is placed on the arm shaft, through the opening in the top of the machine arm, so that the numbers on the disc may be read right side up. Push the arm shaft through the disc about 1 inch.

Arm Shaft Pulley and Arm Shaft Connection Belt

The arm shaft connection belt acts as a sling for the arm shaft pulley. Use the belt and lower the pulley through the opening in the top of the machine arm. Now turn the belt, while aligning the pulley with the arm shaft, and insert the shaft through the pulley. Be sure you push the shaft through as far as it will go.

Arm Shaft Connection Belt Pulley Position Screw

To replace the arm shaft connection belt pulley position screw, you hold the arm shaft in position with the left hand and move the arm shaft pulley to the left. Turn the arm shaft until the hole is facing up. Now turn the pulley until the hole for the

position screw is facing up. Move the pulley to the right, aligning the two holes, and insert the position screw. Tighten the remaining setscrew in the pulley.

Balance Wheel

Before you replace the balance wheel, turn the arm shaft until the groove in the shaft is facing upward. Place the balance wheel on the arm shaft. Now turn the wheel toward the operator until the second screw is directly in line with the groove. Tighten the screw in place. Tighten the remaining setscrew.

Balance Wheel Adjusting Screw

Place the balance wheel adjusting screw in the end of the arm shaft and tighten it. Loosen it one-quarter turn and strike it with a sharp blow using a rawhide mallet. See that the balance wheel turns freely and that there is no play. If the balance wheel does not turn, or if it turns and there is side-to-side play, repeat the procedure.

CAUTION

This balance wheel is made of cast iron or aluminum and will break if you hit it directly with the mallet.

If the screw can be removed by using your thumb and forefinger, it will be necessary to spread the end of the screw. To do this, remove the screw and spread the end of it with a screwdriver. Replace the screw and run it down until it touches the balance wheel. It should then be tightened snugly when you try to remove it with your fingers.

Alternating Presser Driving Rockshaft

Slide the rockshaft into the rear of the machine through the two bushings. Attach the presser- lifting link crank to the link projecting from the arm. Continue sliding the rockshaft through the crank. Set the machine on its balance wheel end. Install the bell crank link on the rockshaft stud (oil holes up). Install the oil guard into the face at this time.

Needle-bar Connecting Link

Turn the balance wheel until the needle-bar connecting link stud is at its lowest position. Grasp the needle-bar connecting link so that the double cylinders are up. Place the larger of the two cylinders over the needle-bar connecting link stud, and ensure that the flush end of the cylinders are facing outward.

Take-up Lever Driving Stud

Place the cylinder of the take-up lever driving stud over the piston of the take-up lever.

Take-up Lever

Grasp the take-up lever with the piston of the take-up lever driving stud and the cylinder of the take-up lever facing the face of the machine. Fit the lever into the slot designed for its operation; at the same time insert the take-up lever driving stud into the remaining cylinder of the needle-bar connecting link.

Thread Take-up Lever Hinge Stud

Align the cylinder of the thread take-up lever with the recess for the hinge stud. Before you insert the hinge stud, turn the hinge stud and note the flat machined-surface running the length of the stud. Replace the stud with the machined surface up. Install the setscrew.

Needle-bar Rock Frame Assembly

Hold the needle-bar rock frame in the left hand with the rounded end up and the straight side facing left. Insert the slide block in the space provided with the oil hole facing up.

Before you insert the needle-bar rock frame assembly, turn the balance wheel until the needle-bar connecting link is at its lowest position. Insert the assembly into the face of the machine so that the connecting stud enters the connecting link and the slide block is placed over the projection on the needle-bar rock frame rockshaft. At the same time, the vibrating presser bar-spring guide rod with the spring attached must be positioned into the hole at the top of the face. Hold the assembly in position.

While you are holding the assembly in position, insert the hinge stud so that the flat surface is up. Install and tighten the setscrew.

Install the needle-bar rock frame. Position bracket in position and tighten it in place.

Thread Tension Release Lever Rod

Insert the thread tension release lever rod in the hole in the back of the machine head so that the rounded end is facing toward the operator.

Presser Bar

Insert the presser bar through the upper bushing located in the top of the machine head, about 3 1/2 inches. Place the presser bar position bar guide lever so that the pinch screw is to the rear and the arm is to the left. At this time the lifting-and-releasing unit must be installed. It consists of a lifting bracket, a releasing bracket, and a spring that separates the two parts. While you are holding the unit together, place it into the face so that the two long levers cover the releasing rod. Now twist

the presser bar down through the unit. Before you lower the presser bar through the lower bushing, insert the presser bar spring bracket with the slot up. Lower the presser bar through the lower bushing. Turn it so that the unthreaded end of the hole faces left. Insert the presser foot in the slot. Replace the screw and tighten it.

Presser Bar Position Guide

Place the slotted end of the presser bar position guide through the opening in the top of the machine head so that it fits over the arm of the presser bar position guide lever. When you complete this step, the top of the presser bar position guide will be flush with the top of the machine head. Tighten the spline screw in the rear of the head.

Presser Bar Spring

Tilt the machine down and place the long curved end of the presser bar spring through the opening in the back of the machine head and into the slot in the presser bar spring bracket. Place the small curved end over the presser bar spring-support screw. Push it down and under the presser spring-regulating screw. Tighten the presser bar spring-support screw. Install the large guide screw.

NOTE: Preadjust the spring bracket with the presser foot firmly on the throat plate, and make sure the foot is straight. Raise the presser bar spring bracket about one-eighth inch and tighten the pinch screw.

- At this time, adjust the presser bar guide lever one-quarter inch up from the bottom of the guide as in figure 7 (K).
- Tighten the pinch screw (figure 11 [B]).

Front Presser Bar Connecting Link

Place the large end of the line on the front presser bar stud.

Bell Crank

The bell crank has three attachment points: (1) the bell crank connection link, (2) the lifting lever bell crank stud, and (3) the front presser bar connecting link stud. All three must be engaged at the same time. Install and tighten the retaining screw.

Front Presser Foot and Presser Pressure-Regulating Thumbscrew

Install the foot on the front presser foot and the regulating screw on the top of the face.

Knee Lifter Lifting Lever

Replace the knee lifter lifting lever so that the slotted end fits over the projection on the knee lifter connection lever. The projection on the curved end of the knee lifter lifting lever fits under the presser bar releasing bracket.

Knee Lifter Lifting Lever Hinge Screw

Align the hole in the knee lifter lifting lever with the corresponding hole in the machine arm; then insert the hinge screw. Make certain the screw, including the shoulder, is fully inserted.

Faceplate

Insert the thumbscrew and secure it.

Arm Cap

Replace the arm cap and the spring washer on the machine arm and screw them in place.

This completes the reassembly of the 111W155 sewing machine. It will be necessary to make a few minor adjustments or retime this machine. Timing and adjustment are covered earlier.